

# Putting Serial Attached SCSI to Work for You

---

## INTRODUCTION

*Over the past three years, Serial Attached SCSI (SAS) has been unveiled as the next evolution of the SCSI standard — featuring increased performance, scalability, and reliability, while maintaining ease-of-use and the SCSI feature set that has made SCSI the de facto standard in enterprise computing environments. The first SAS products are starting to become available, and represent the first step in making SAS a widely adopted technology standard.*

*This guide from Adaptec will help you understand Serial Attached SCSI: what it is, how it works, how it can help you get higher storage performance at a lower price point, and how to put this transition to the best use for your existing storage and future storage needs.*

*For many years Adaptec has been the leader in SCSI products and technology, and is bringing this expertise to the SAS market. During the transition to SAS, count on us to provide you with the information you need to use this technology and get the most from your storage investment.*

## Moving to Serial Technologies

Parallel SCSI technology has been the widely deployed standard in server and storage data centers for the last 20 years. While parallel SCSI has been a reliable standard interface, the technology has reached its highest performance level with the advent of Ultra320. As servers are pushed to meet advancing system and application computing requirements, parallel SCSI has struggled with signal skew and crosstalk, signal termination restrictions, cable and connector reflections, and device addressability — all of which have become barriers to next-generation throughput performance.

Industry leaders in server and storage computing have been working together to overcome this throughput performance challenge. The result of this intensive investigation has resulted in transitioning parallel SCSI to a serial interface. Serial technology transmits data in a single stream instead of the multiple streams found in parallel technology, therefore it is not tied to a particular clock speed and can transfer data at a much higher rate (up to 30 times faster) than parallel technology. It also offers greater reliability and scalability.

Serial technology is not new. In fact, the SCSI evolution was based on the widely pervasive serial network already deployed in the datacenter. In the late 1990s, storage utilization and growth were critical issues facing the datacenter. The result was proposals and products that aggregated storage on a dedicated ‘storage network’. This helped IT managers to consolidate and effectively manage and grow their aggregated enterprise data pools. Yet, successful implementation required long distance support and high speed with minimal latency to provide rapid access to critical information that was now consolidated away from the data center. The answer was Fibre Channel, the first serial technology to gain significant momentum in the mainstream enterprise marketplace.

By 2002, storage networks had become pervasive in the enterprise. Yet the amount of information continued to grow, in response to the efficiency of these networks and the user perspective that all data is critical data. This organic data growth coincided with strict new government data retention requirements (e.g. Sarbanes-Oxley) that meant that a new “class” of storage — non-mission-critical data — had to be kept readily accessible for a number of years. So, the industry wrestled with the next major technology requirement, a way to cost-effectively manage the exploding amount of storage content in the IT infrastructure.

Cost became the principle focus. Solution vendors and industry leaders responded with the introduction of Serial ATA (SATA), which serialized the low-cost, high-volume desktop-class ATA hard drives with a new interface that provided adequate reliability and performance for non-mission-critical information. Companies with data protection expertise, such as Adaptec, responded by helping to drive best-in-class RAID technology, that when paired with SATA hard drives, provided optimized technology at a much lower cost. SATA also provided higher disk interconnect speeds of 1.5Gb/s (SATA I) and 3Gb/s (SATA II). The future is exciting for SATA, as speeds continue to increase (up to 6Gb/s in the future) and some enterprise capabilities will be enhanced, including hot swap and simplified cabling. Meanwhile, the technology will maintain the ATA family commitment of driving the lowest acquisition cost per megabyte for enterprise IT centers.

## Putting Serial Attached SCSI to Work for You

*SAS delivers the high performance, scalability, and reliability required for bandwidth-hungry mainstream servers and enterprise storage.*

*SAS lends itself to the high-frequency, immediate random data access required for transactional data applications such as online purchases and bank transactions and provides the performance and security required for mission-critical applications which demand data redundancy.*

*“Adaptec validates the vision of the Serial Attached SCSI standard – with its SCSI technology leadership, comprehensive understanding of reseller and end-user requirements, and a broad range of products that can be mix-and-matched into SAS-based solutions that meet a new range of storage performance and pricepoint needs.”*

*Greg Schulz, Sr. Analyst,  
The Evaluator Group*

### What is Serial Attached SCSI?

Finally, the most pervasive enterprise technology has come to a crossroads. Parallel SCSI is the heart of the datacenter, used as the standard interconnect and hard drive communication scheme for server and storage environments. Companies had been developing and utilizing SCSI for over 20 years as the mainstay for enterprise storage.

But the technology’s future was coming into question. Quite simply, the parallel interface would have to be overhauled to address next generation concerns of signal integrity, performance and reliability, right down to fundamentals like cable length.

The result of three years of industry discussions and technological investigation is Serial Attached SCSI (SAS), the next standard in enterprise server and storage technology. SAS is a high-performance solution that leverages proven SCSI functionality, and builds on the enterprise expertise of multiple chip, board, drive, subsystem, and server manufacturers throughout the industry. It provides better performance and flexibility than the serial technology, Fibre Channel, at a lower cost and with the same, or ever better, reliability.

#### Key SAS Features Include:

- SAS and SATA drive support providing an unprecedented level of choice in the enterprise — the flexibility of integrating either SAS and/or SATA devices in common server or storage solutions, providing customization to meet cost or performance needs in unique business environments
- reliable point-to-point connections at 3Gb/s — up to 128 devices (or 16,256 addressable devices per port)
- full dual-ported connections for performance or failover capabilities, delivering robust data protection and reliability right to the hard drive
- enterprise features including native command queuing and greater than 2TB LUN support
- available in multiple hot-swappable disk drive performance and form factor configurations including high value 3.5” 10k rpm drives, high performance 3.5” 15k rpm drives and emerging 2.5” high density drives for performance server and specialized high-performance storage applications
- thinner cabling than SCSI and ATA which delivers new cooling metrics and more efficient airflow — critical in a dense computing environment where low profile servers are racked and stacked with multiple external storage chassis. Effective heat management and cooling schemes remain a top priority for IT managers today delivering enhanced uptime and reliability guarantees in application sensitive environments.

SAS delivers the high performance, scalability, and reliability required for bandwidth-hungry mainstream servers and enterprise storage. SAS lends itself to the high-frequency, immediate random data access required for transactional data applications such as online purchases and bank transactions and provides the performance and security required for mission-critical applications which demand data redundancy.

Most importantly, IT managers today cannot risk deploying the wrong type of solution. Today, server or storage solutions represent finite choices — you must choose early on whether you want a SATA-optimized server or storage solution, or whether you will pay more upfront for a parallel SCSI optimized server or storage solution. If you deploy the low-cost SATA solution, but the performance and reliability metrics fail to meet internal user expectations and uptime service guarantees, the choice is straightforward — pick a weekend, forklift upgrade the application and storage infrastructure, and hope that you

## Putting Serial Attached SCSI to Work for You

can redeploy a new SCSI-based solution before the weekend is through. This does not account for the vendor negotiation of taking back the ‘slightly used’ SATA solution, and replacing it with a SCSI solution.

SAS breaks these barriers. Deploying standard server and storage chassis based on SAS architecture makes it easy to purchase and maintain service spares by leveraging common components (power supplies, memory, etc.), and ensures that IT staff is up to speed and very comfortable with the server and storage solution.

The most compelling part of SAS is that the datacenter manager can now customize the type of storage for an environmental infrastructure. If the application is not mission critical or consumes capacity at an unmanageable pace, SATA hard drives can be deployed into the SAS ecosystem, which is able to auto-negotiate with both SATA and SAS hard drives. If needs change and performance and reliability become the dominant requirement, the IT manager can simply migrate existing SATA hard drives to more robust SAS hard drives, then redeploy the SATA technology into another server or storage farm. All this can be done without having to forklift upgrade or disrupt the application server or storage chassis.

### Serial Attached SCSI Market Overview

Today, in the \$13 billion storage marketplace, three dominant technologies account for the lion’s share of sales: SCSI, Fibre Channel, and SATA.

As shown in *Figure 1*, current technology requires the use of different hard disk types to meet the needs of the common range of applications. Each hard disk type must use a controller with the same interface type. For example, a high-end performance system based on Fibre Channel disk drives requires a Fibre Channel controller interface. Some Fibre Channel deployments are Storage Area Networks (SANs) in which large data centers have deployed a dedicated high speed network and require dual redundant paths right to the hard drive to ensure reliability and performance.

An affordable low-end SATA storage solution requires both SATA hard disks and a controller with a SATA interface. This inflexibility limits your choice in solutions and forces tradeoffs in your storage, such as performance and cost.

In contrast, SAS will become a nearly universal interface, dramatically changing the storage landscape and dominating market share and revenues. As shown in *Figure 2*, SAS will give you new, more cost-effective performance options for the high-end applications currently dominated by expensive Fibre Channel solutions. A SAS backplane also supports SATA disk technology, allowing you more flexibility in the solutions you can fit into one common storage enclosure. It also provides investment protection: start with low-cost SATA drives, then migrate to SAS drives as needs change, for Fibre Channel-comparable performance in the same enclosure. In fact, for many business solutions, SAS allows you to more finely tune the relationship between performance and price point while dramatically simplifying overall system management.

The transition from parallel SCSI and Fibre Channel technologies to SAS is starting right now, with SAS being integrated into solutions that will be ramping in 2005. In fact, SearchStorage has forecast that this year SAS will become the hottest direct attached storage (DAS) connection technology. Quite simply, by the end of 2005, SAS will be the industry’s fastest growing storage technology.

### Storage Connectivity Market Today

Applications	Disk Drive Type
High-end	Fibre Channel
Mid-range	SCSI
Low-end	SATA

*Figure 1: Today, applications are addressed by specific drive types.*

### SAS Impact on Storage Connectivity

Applications	Disk Drive Type
High-end	Fibre Channel
Mid-range	SCSI
Low-end	SATA

} SAS

*Figure 2: SAS gives you new flexibility to choose the drive performance requirements needed at any point-in-time at a price point that makes sense for your budget.*

## Putting Serial Attached SCSI to Work for You

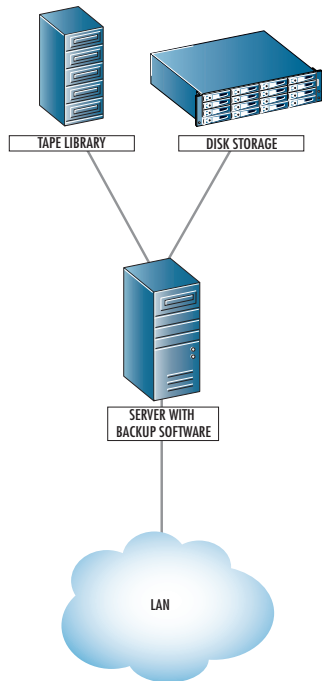

*One Common Disk-to-Disk-to-Tape Solution*

### Economics of Serial Attached SCSI

SAS provides SCSI-like price, performance, and reliability points between Fibre Channel and SATA to give you more flexibility in choosing solutions. Table 1 illustrates the cost differentials between these three technologies on an identical disk-to-disk-to-tape configuration. An approximation of a sample configuration is used in the example in Table 1 to illustrate the cost/performance benefits of SAS in this solution. Keep in mind that a SAS drive can read and write at least twice as fast as SATA.

	Fibre Channel	Serial Attached SCSI	Serial ATA
Tape Library	~\$20,000	~\$20,000	~\$20,000
Drives	2	2	2
Media	SDLT 320	SDLT 320	SDLT 320
1U Server	~\$4000	~\$4000	~\$4000
Cabling & Controller	~\$500	~\$500	~\$500
Backup Software	~\$1000	~\$1000	~\$1000
Accessory Cost:	~\$25,500	~\$25,500	~\$25,500
Disk Array			
RAID Controller	Dual Redundant	Dual Redundant	Dual Redundant
Disk Drives (3TB)	10x300GB	10x300	12x250GB
Enclosure/Drive	FC/FC	FC/SAS or SATA	FC/SATA
Disk Storage Cost:	~\$40,000	~\$20,000	~\$18,000

Table 1. Sample configuration pricing based on March '05 pricing from several major catalog reseller websites. Items priced were 3TB Adaptec storage enclosures, HP Windows-based servers, VERITAS Backup Exec with library support, and a 3TB Quantum M1500 library.

Remember that the actual cost of any of these technologies is more than the cost of acquisition, and you need to look at the Total Cost of Ownership (TCO) or what you will need to invest in deployment, maintenance, and administration costs. Take Fibre Channel, which has a high acquisition cost and a high TCO, for example. This combined cost means that Fibre Channel deployments usually are found in SANs, and that you are investing heavily in a dedicated high-speed network to enhance storage reliability and performance, including more efficient movement of information over multiple locations. The implied TCO costs usually include dedicated storage IT staff that requires extensive FC and SAN training, the expense of multiple software technologies being utilized to track and manage the effectiveness of SAN data movement, the cost of the cabling infrastructure, and depending on replication and remote location integration, the ability to replicate data over a carrier's long distance fibre network. This means that acquisition and TCO costs are high for a SAN, which has limited its wide market adoption into mainstream datacenters around the world.

Similarly, SATA configurations offer performance trade-offs. Though SATA provides the lowest initial acquisition cost, it does not offer mainstream enterprise feature functionality. SAS, however, delivers a compelling value proposition for the mainstream IT datacenter — the benefits of lower costs, high performance, and flexible hardware configurations, improved margins and customer satisfaction on nearly any storage solution. Keep in mind also that if you are using SAS, you can continue to use that enclosure for a different purpose as storage needs change over time, creating a compelling TCO value proposition.

### Mix and Match Architectures for Flexible Cost Structures

The value and flexibility of SAS enables a variety of new storage solutions that haven't been possible before:

- Highly reliable, high-performance primary storage for small and medium businesses who can't afford a Fibre Channel solution.

## Putting Serial Attached SCSI to Work for You

5

- Make the best use of your Fibre Channel investment by offloading less-valuable data to a high-performance, high-reliability system with SAS and/or SATA drives and a Fibre Channel HBA interface.
- Get more storage in the same space with higher-density solutions, made possible since four small form-factor SAS drives will fit into the same enclosure that today holds only three drive bays.
- Integrate low-cost SATA drives into your SAS-based solutions and still take advantage of the performance and reliability of the SAS connection for more cost-sensitive situations.

### When to Choose SCSI, Fibre Channel, or SAS?

Although SAS will become the dominate standard, and should become part of your storage plan, for the foreseeable future, SCSI, Fibre Channel, and SAS will co-exist. As we have done during previous technology transitions, Adaptec will continue our industry-leading support for both the existing and new technologies.



*Figure 3: SAS will become the technology of choice for most storage needs, while coexisting with FC and SATA for very high end, or very cost-conscious requirements.*

If you have invested in a Fibre Channel infrastructure, beginning your transition to SAS enclosures now allows you to increase storage scalability and flexibility, while maintaining Fibre Channel connectivity to the network.

If you have invested heavily in an extensive parallel SCSI infrastructure that you are looking to maintain, for the moment, it makes sense to continue to rely on your trusted SCSI solutions.

Think about transitioning to SAS sooner rather than later if you

- Want to simplify the datacenter — standardize on a SAS-based server or storage chassis
- Are seeking a long-term strategic storage solution
- Need a lower TCO
- Need high-performance, enterprise features and value pricing
- Are ready to transition to networked storage for the first time
- Are ready to adopt the new standard instead of investing further in an Ultra320 standard that has reached the end of its development
- Need the flexibility of SAS for a multi-use storage solution

### Serial Attached SCSI Implementations

SAS components will be available from all of the major disk drive vendors, host adapter suppliers, storage suppliers, chipset manufacturers, large computer makers, and many other companies. With these solutions, you can take advantage of the increased flexibility, reliability and performance of SAS components. This section gives you a glimpse into the types of solutions that will be available using SAS components.

## Putting Serial Attached SCSI to Work for You

### SAS Components and Systems

#### Host Bus Adapters:

SAS host bus adapters (HBAs) feature 300MB/s connections. Multiple ports increase the total available bandwidth; as an example, an eight-port HBA would provide a total bandwidth of 4800MB/s.

Another new feature to look for when choosing an HBA is the newest RAID level — RAID 6. RAID 6 data protection offers twice the fault tolerance of RAID 5. A machine protected by RAID 5 can only sustain the failure of one hard drive and is vulnerable to data loss if another drive fails while the array is rebuilding and in the degraded mode. A machine protected by RAID 6 can sustain two drive failures, and therefore is far more available than other RAID levels. This is ideal for SATA environments which can be susceptible to drive failure. The cost of RAID 6 is only one additional disk drive, a small price to pay for this significantly improved protection.

#### Disk Drives:

One of the benefits of the SAS interconnect technology is its ability to support both SAS and SATA drive types. This offers the flexibility to hit a price point with low-cost lower-performance SATA drives, and also provide maximum performance and reliability using SAS drives; achieving the right balance between cost, performance, and reliability.

SAS disk drives are dual-ported, like Fibre Channel drives. SAS drives are also rated at the same reliability level as SCSI and FC hard drives, meeting your most demanding reliability and availability needs.

SAS provides a high-speed, high-density alternative to SCSI. As such, the first places it is being deployed will be in point-to-point solutions, such as DAS and clustered storage scenarios. These first SAS topologies will deploy SAS internally while still relying on Fibre Channel or iSCSI for interconnecting external storage enclosures.

#### Internal Enclosures:

SAS enclosures can accommodate SAS or SATA disk drives. Using SAS drives in an enclosure provides highly reliable and highly available storage, suitable for primary storage solutions. Initial capacity provided by a SAS enclosure can be easily increased with SAS expansion arrays.

Using RAID 6 in conjunction with an enclosure provides higher availability levels than RAID 5, making it suitable for primary storage even if lower-cost SATA disks are used instead of SAS disks.

#### Expanders:

SAS expanders will be introduced and will enable external SAS storage enclosures to span multiple host initiators and external enclosures. This will allow the creation of large scale SAS-based solutions; expanding far beyond the number of drives and unit numbers SCSI can support today. When coupled with RAID 6, these configurations can create high-performance, highly scalable, and highly available solution sets.

#### External Storage Arrays with Internal SAS/SATA Disk Drives:

External storage arrays are currently available with SCSI, SATA, and FC disk drives. Adding the capability of SAS drives provides additional flexibility to configure high-performance, high-reliability solutions and/or low cost, high-density solutions, depending on the intended application and reliability needs.

# Putting Serial Attached SCSI to Work for You

7

## Solutions

### 1. High-Performance Internal Direct Attached Storage (DAS)

**Application:** High-availability, high-reliability internal storage for workstations and servers

This solution uses a SAS RAID HBA with either internally connected point-to-point drives, or using a four-drive-bay, 5.25" internal enclosure, and is ideally suited for:

- Applications that require high availability through mirroring
- High-reliability solutions through the use of SAS drives
- High-performance demands that can take advantage of SAS throughput
- Applications that require point-to-point connections within the server chassis with simplified cabling
- CAD/CAM/CAE or modeling applications
- Small capacity databases
- Workstation-based video and audio capture and editing

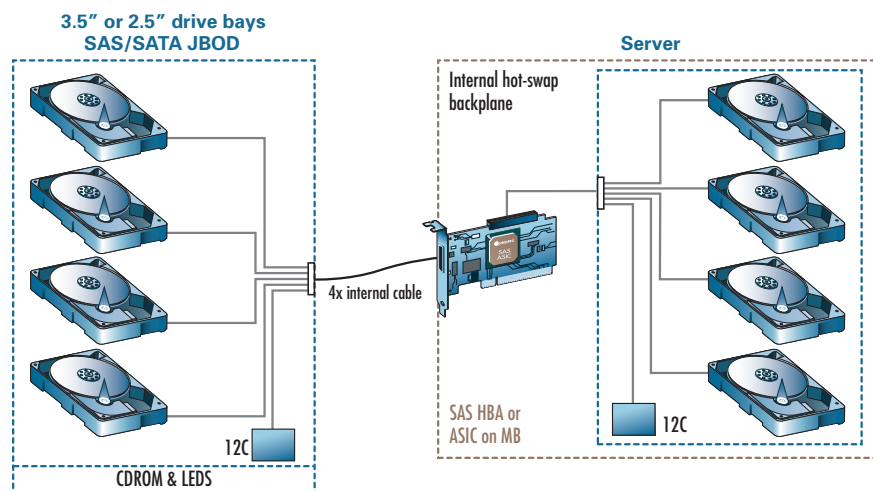

#### Solution Elements:

Servers

SAS RAID HBA

External or internal SAS/SATA hard drives or internal four-drive chassis with disk drives

### 2. High-Performance, Highly-Available, and Scalable DAS

**Application:** Easy scalability for databases and other continually growing datasets

As illustrated, this solution combines the highest performance, highest availability through a comprehensive RAID set, and highest scalability available for direct attached storage (DAS). In this example an 8-port RAID HBA is used. In its simplest form, an internal four 3.5" drive 5.25" chassis can also be used with the HBA, for storage requirements internal to the server. For higher capacity needs, a SAS external JBOD enclosure can be connected to the HBA.

SAS provides higher scalability than the existing SCSI standard and is similar to Fibre Channel. Simply daisy chain JBODs to the RAID card to add capacity.

With the external enclosure and SAS drives, this solution is ideal for enterprise-class primary storage applications with high availability needs, including data warehousing, databases, and decision support, in any demanding application environment.

## Putting Serial Attached SCSI to Work for You

8

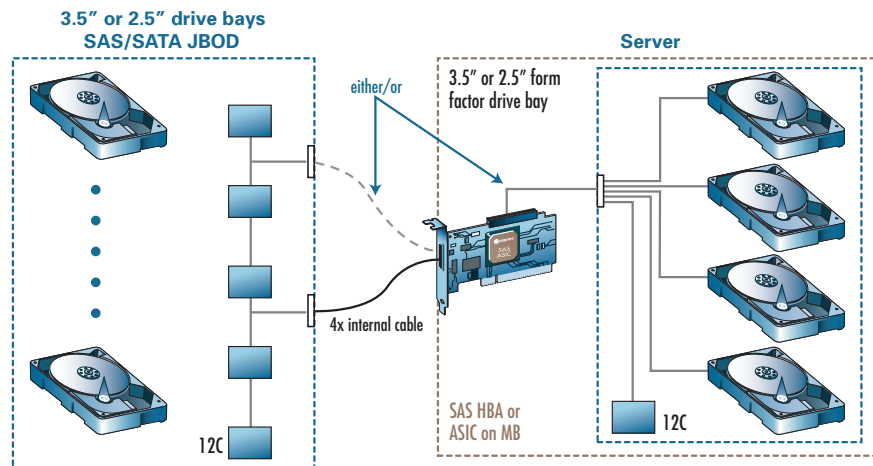

### Solution Elements:

Server

8-port SAS RAID HBA for 4800MB/s total bandwidth

RAID levels 0, 1, 5, 6, 10, 50

JBOD enclosure that can be daisy-chained to additional arrays to increase capacity

Cable redundancy due to dual connectors and dual controllers in the external enclosures

Internal four-drive 5.25" chassis

### 3. High-Performance SAS Server Clusters

#### Application: Reduced-cost failover without performance loss

This solution provides an alternative to clustered Fibre Channel local loop topologies — high performance and high availability with no single point of failure. It can be implemented using a SAS ASIC (mounted on the motherboard) or SAS RAID HBA. The hosts share a storage pool on the SAS JBOD enclosure, which supports either SAS or SATA drives. The storage pool can be easily scaled with the addition of more disks or extra JBODs. Dual controllers with multi-path I/O support and RAID 6 provide the highest availability, even with low-cost SATA drives.

Ideal for applications including:

- High-performance enterprise cluster configurations
- Business-critical primary storage
- Data warehousing
- Video and audio streaming



## Putting Serial Attached SCSI to Work for You

9

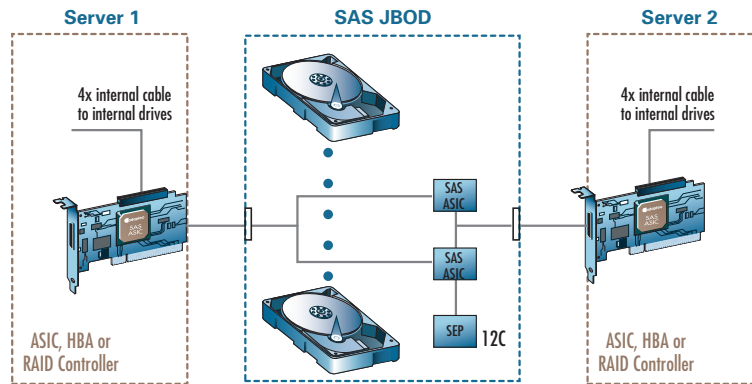

### Solution Elements:

Servers with support for multi-path I/O (MPIO) support if path failover is required on the same server

Cluster Software — single or dual SAS controllers and cluster software per node in the cluster

SAS ASIC or SAS RAID HBA

JBOD external enclosure

### 4. Highly-Scalable SAS-based Storage Solution

#### Application: Future storage growth and flexible disk usage

Once SAS expanders become available, this highly scalable, high-performance solution will become possible across a wide variety of reliability and availability points.

The two servers, equipped with single or dual SAS RAID HBAs share a large storage pool composed of SAS JBOD enclosures daisy-chained using SAS connections. Both the host storage and storage pool are highly scalable, as each SAS expander can connect up to five chained JBOD enclosures. Cascading the expanders, as shown, greatly increases the number of devices that can be addressed. Dual redundant paths are created through the external disk enclosures directly to the disks. SAS drives or SATA drives can be used. Also, adding RAID 6 further increases the availability of the configuration.

It is ideal for enterprise data centers that require the connectivity of medium-sized SAN configurations for applications including:

- Business-critical primary storage applications with no single point of failure
- Data warehousing
- Video and audio streaming
- Primary databases

## Putting Serial Attached SCSI to Work for You

10

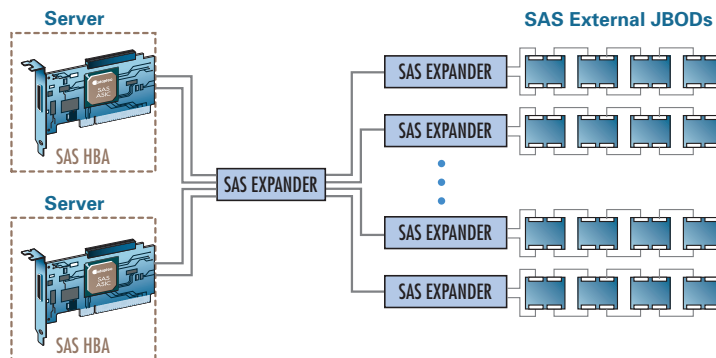

### Solution Elements:

Servers

Dual SAS controllers — either controller will work, depending on application needs

Cascaded external SAS expanders, when available

Daisy-chained SAS JBOD enclosures

Dual-redundant paths directly to SAS disks

Expansion for up to five enclosures per expander

Scalable, SAN with SAS/SATA disk drives

### 5. High-Performance, Highly-Available, and Scalable Fibre Channel SAN with SAS/SATA disk drives

**Application:** Fibre Channel SANs with the flexibility to choose the performance of SAS disks or low-cost, high-density SATA disk drives

This solution combines a Fibre Channel switch, Fibre Channel host bus adapters, and an external array that can be used with SAS or SATA disks to build a complete SAN.

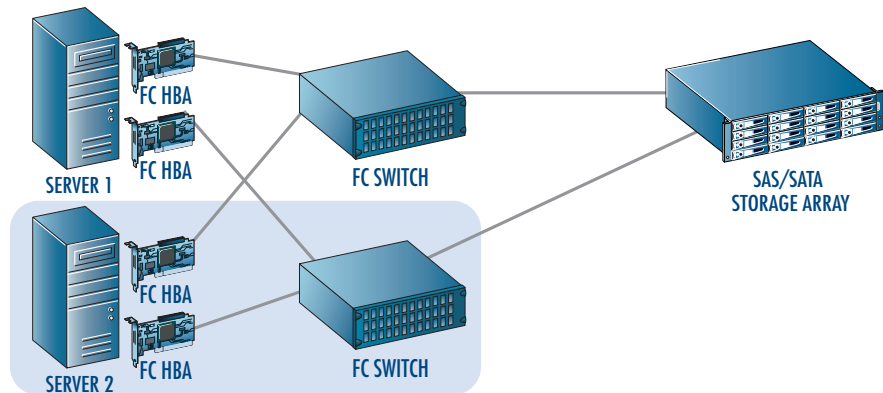

### Solution elements:

Two Servers

Two Fibre Channel HBAs

Fibre Channel Switch

12-Drive SAS/SATA RAID external enclosure with single or dual controller options

## Putting Serial Attached SCSI to Work for You

11

### 6. Scalable, SAN with SAS/SATA disk drives

**Application:** IP SANs with the flexibility to choose the performance of SAS disks or low-cost, high-density SATA disk drives

This solution combines a Gigabit Ethernet switch, an iSCSI host bus adapter (HBA), and an external array that can be used with SAS or SATA disks to build a complete SAN.

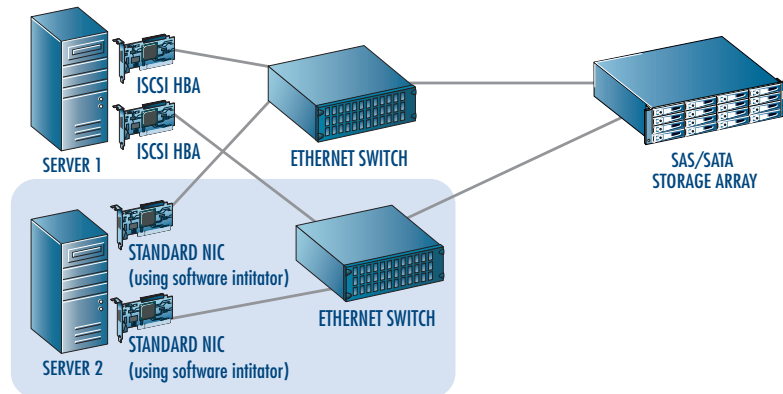

#### Solution Elements:

Servers

Optional iSCSI HBAs (one or many)

Optional software iSCSI initiator

Gigabit Ethernet Switch

12-Drive SAS/SATA RAID external enclosure with single or dual controller options

#### Adaptec: Leading the Transition to Serial Attached SCSI

As the worldwide leader in SCSI technology, Adaptec is bringing its 24 years of expertise in development and continual improvement of SCSI to SAS. We are developing one of the industry's broadest families of SAS and SATA products, including, HBAs, RAID controllers and external storage disk array, based on our Flexible Storage Architecture (FSA). FSA allows our customers to easily and seamlessly mix and match drives, creating storage solutions that offer the right balance of cost, performance, and connectivity for any network, infrastructure, and storage opportunity.

When you choose Adaptec for your SAS solutions, you get the expertise of the most trusted name for SCSI technology and products you know will integrate easily with each other and with your existing networks and infrastructures. You can even take advantage of a single software management and driver set throughout your configuration.

Adaptec offers you the simplest, most reliable transition to SAS. To learn more about Adaptec Trusted SAS solutions, visit [www.adaptec.com](http://www.adaptec.com).

**adaptec**

Adaptec, Inc.  
691 South Milpitas Boulevard  
Milpitas, California 95035  
Tel: (408) 945-8600  
Fax: (408) 262-2533

#### Literature Requests:

US and Canada: 1 (800) 442-7274 or (408) 957-7274

World Wide Web: <http://www.adaptec.com>

**Pre-Sales Support:** US and Canada: 1 (800) 442-7274 or (408) 957-7274

**Pre-Sales Support:** Europe: Tel: (44) 1276-854528 or Fax: (44) 1276-854505

Copyright 2005 Adaptec Inc. All rights reserved. Adaptec and the Adaptec logo are trademarks of Adaptec, Inc., which may be registered in some jurisdictions. All other trademarks used are owned by their respective owners.

Information supplied by Adaptec Inc., is believed to be accurate and reliable at the time of printing, but Adaptec Inc., assumes no responsibility for any errors that may appear in this document. Adaptec, Inc., reserves the right, without notice, to make changes in product design or specifications. Information is subject to change without notice.

P/N: 666829-011 Printed in USA 06/05 3918\_1.2